

+

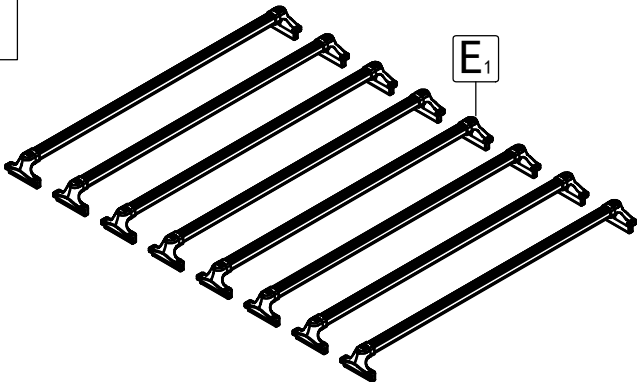

+

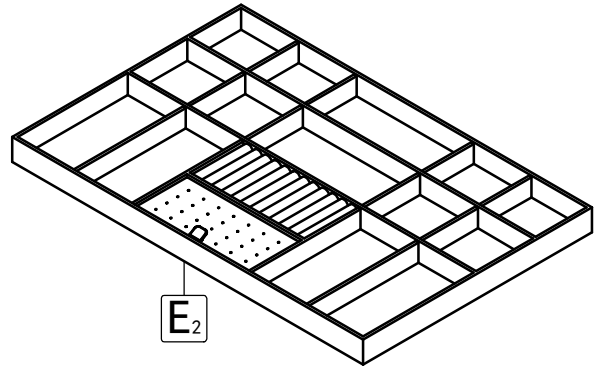

+

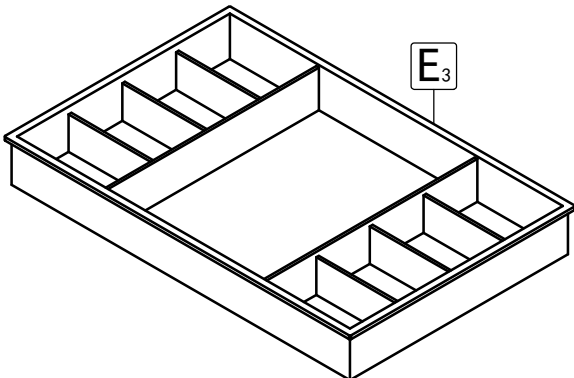

+

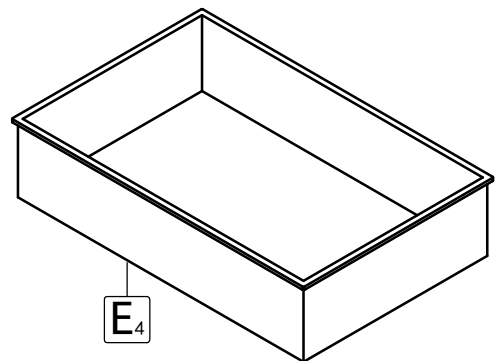

+

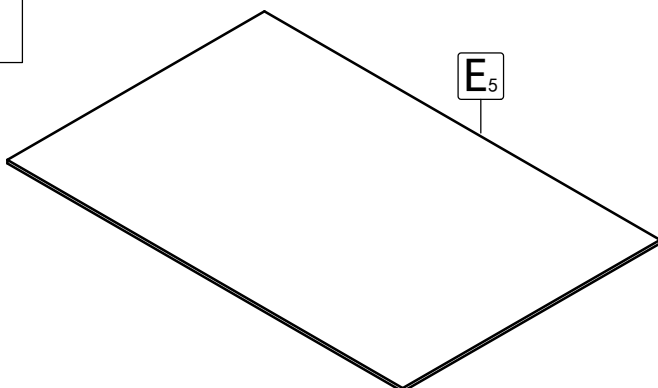

+

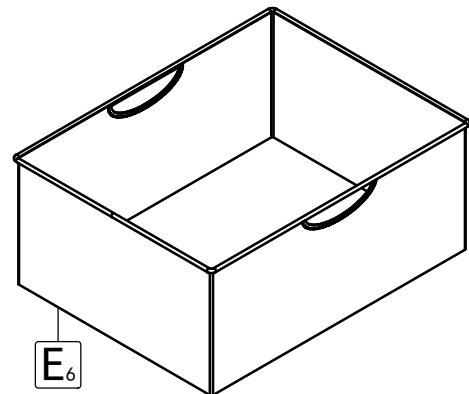



1

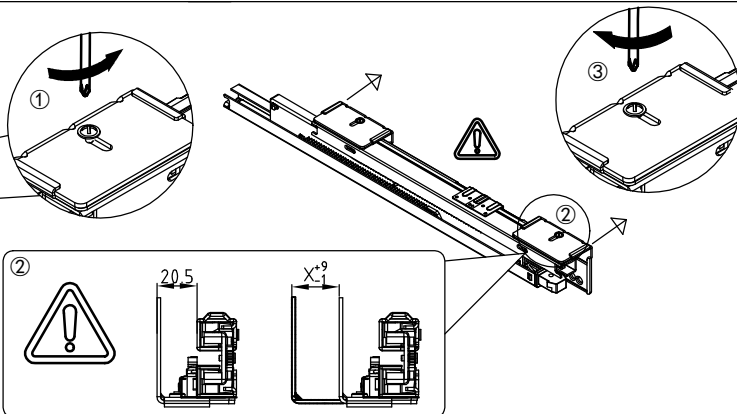
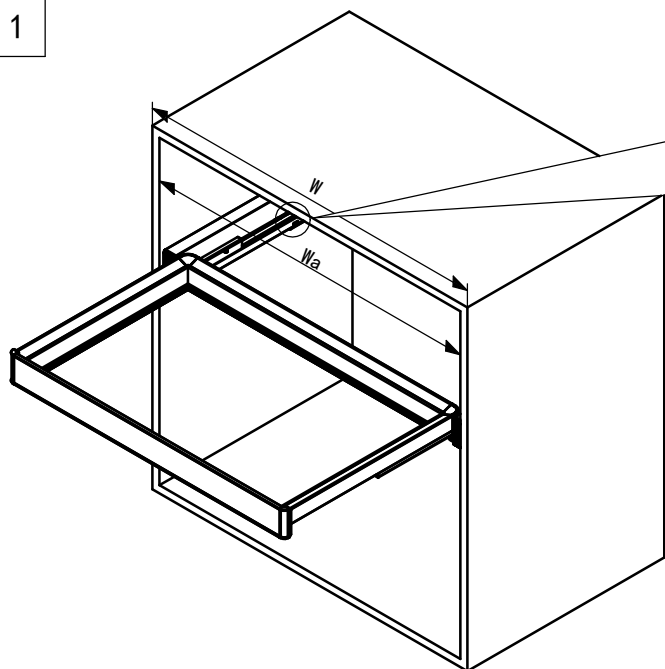

Wa	W	Wa	W
362-382	400	962-982	1000
462-482	500	1062-1082	1100
562-582	600	1162-1182	1200
662-682	700		
762-782	800		
862-882	900		

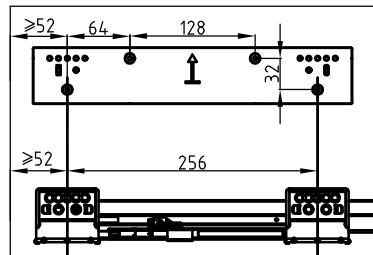

2

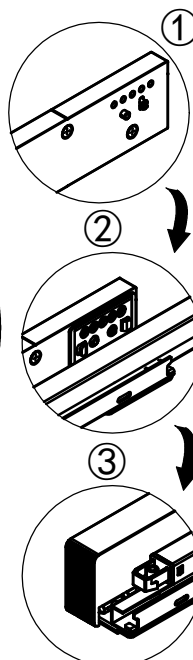
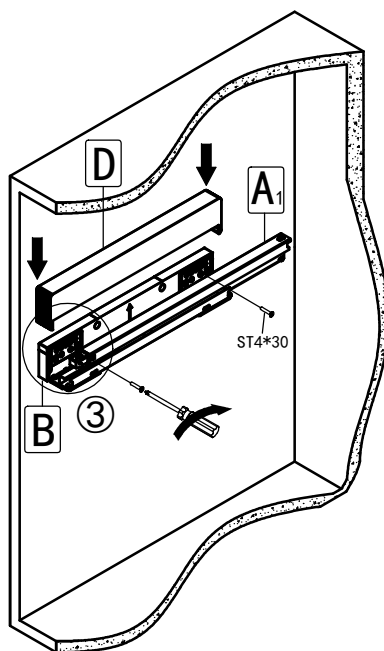
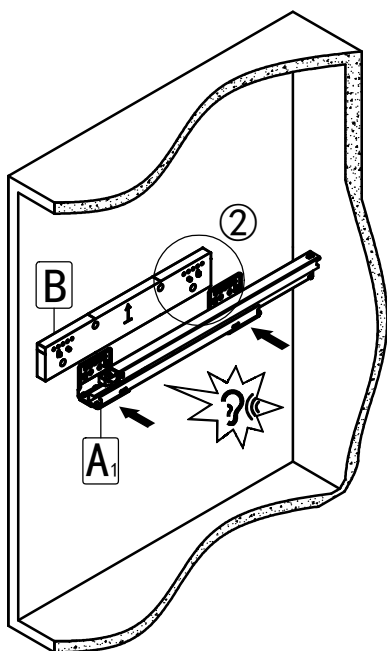
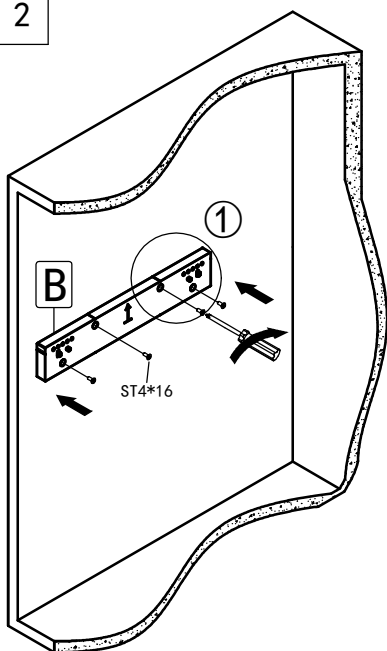

3

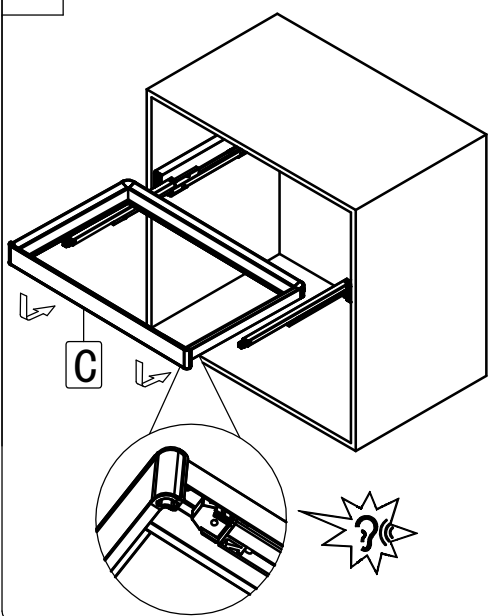

4

